



# IQ4 Vertical Fall - Throat Metal Detector

Designed for the Food Industry

## Product Highlights

- Gravity feed system for inspecting powders, granules or bulk food products
- Supplied complete with frame, throughput tube and choice of sealed valve or cowbell reject devices
- Tivar anti-static food grade throughput tube as standard
- Air failure and dump valve features included
- Four password protected security levels are provided for Operators, Supervisors, Engineering and Administration

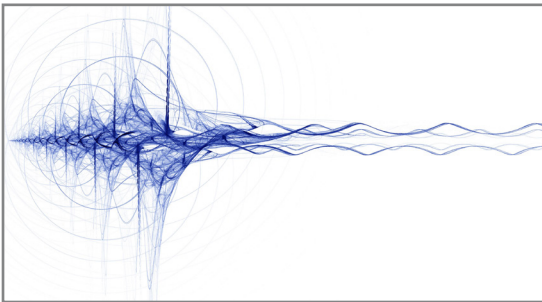

### Variable Frequency Provides the Best Detection Levels

The IQ4 Vertical Fall is built using LOMA's Variable Frequency technology that allows detection levels to be optimised around a wide range of differing product conditions



### Auto Learn Provides Simple and Fast Set-up

The IQ4 Vertical Fall will automatically set-up and store up to 200 different presets, calibrating for product effect and loose material as the product passes through the system.

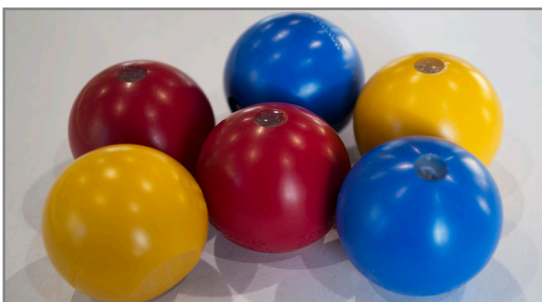

### Best in Class Detection Levels for Magnetic and Non-magnetic Metals

The IQ4 Vertical Fall offers excellent detection levels

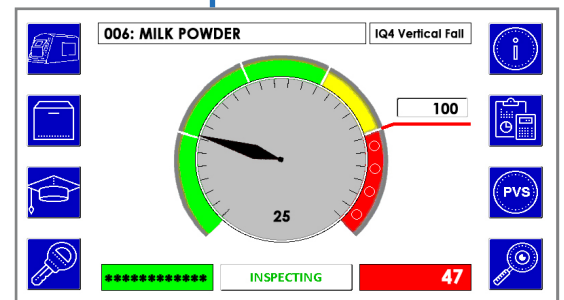

### 7" Colour Touchscreen

Standard across all of the IQ4 range, the big 7" touchscreen offers 33% more space than previous generation metal detectors making operations simple.

# Technical Specification

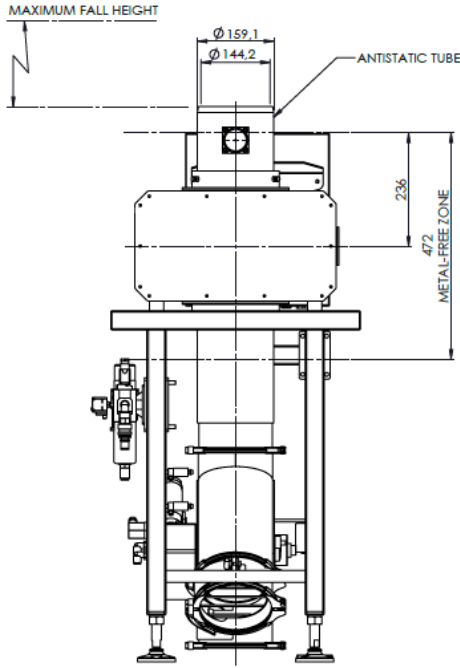

Nominal Diameters Available (mm)	100 (4"), 150 (6"), 200 (8"), 250 (10")
Material of Construction	304 Brushed stainless steel
Variable Frequency	31 to 882 kHz
Supply Voltages	110 - 250V AC 50/60Hz
Power Consumption	20VA
Temperature Range	-5 to 40°C (23 to 104°F)
Humidity	0 to 95% Relative Humidity (Non-condensing)
Environment	IP65 (System) IP69K (Head, Tube & Electronics)
PVS Enabled	Yes
Ethernet Capability	Yes
USB Capability	Yes

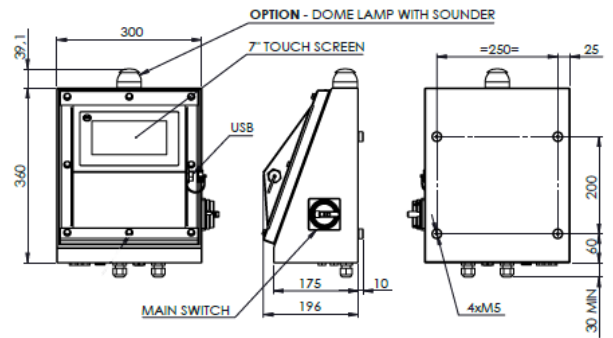
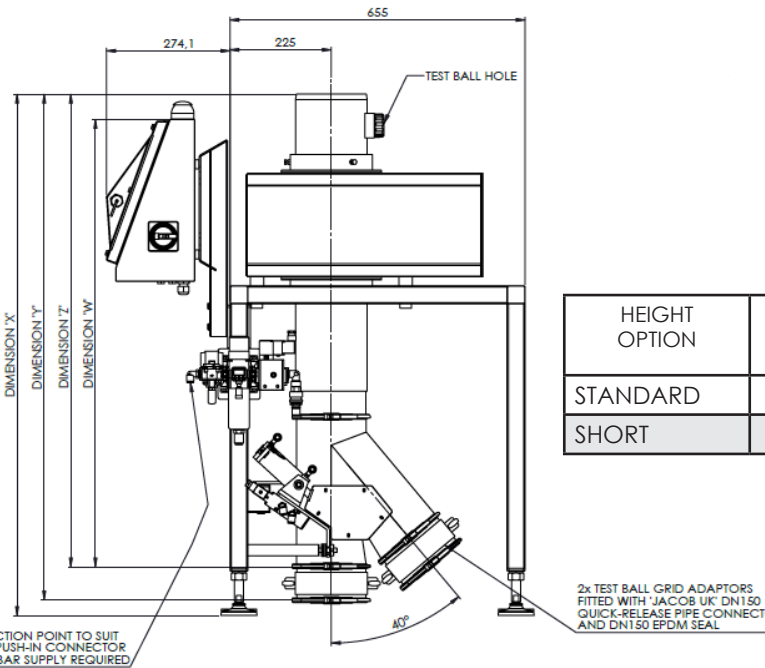

HEIGHT OPTION	DIMENSION 'X'	DIMENSION 'Y'	DIMENSION 'Z'	MAXIMUM FALL HEIGHT	DIMENSION 'W' MIN-MAX
STANDARD	1157	1122.5	1049	800	945 - 995
SHORT	1001	966.5	893	200	785 - 835

Typical dimensions shown (using a 150 mm diameter system). All dimensions in mm

## Automatic Reject Options

The IQ4 Vertical Fall can be supplied with either of the below reject options:

- Sealed Valve
- Cowbell



An ITW Company

[www.loma.com](http://www.loma.com)

Tel: +44(0)1252 893300 (UK) | +1-800-872-LOMA (North America)

**Metal Detection | Checkweighing | X-Ray Inspection**

Loma Systems is a registered trademark of Illinois Tool Works Inc. (ITW). Other names, logos, icons and marks identifying our products and services referenced herein are trademarks of ITW and may not be used without the prior written permission of ITW. Other product and company names listed are trademarks or trade names of their respective companies. Copyright © 2018 Illinois Tool Works Inc. All rights reserved. All of the specifications shown in this document are subject to change without notice.

In association with

