

Scanvaegt SB520 ScanBatcher

Precision batching



HIGH UPTIME
UNBEATEN ACCURACY
HYGIENIC DESIGN

The Scanvaegt SB520 ScanBatcher is the next generation dynamic weighing machine, which represents a fast, cost-effective and sturdy solution for various applications e.g. minimum batching, tolerance batching and sizing.



Stepping-up batching and grading

Based on decades of experience with weighing machines for batching applications the new SB520 stands on solid grounds.

Featuring the new enhanced software, a state-of-the-art HMI and the reliable design that withstands use in wet and harsh production areas, the SB520 represents a powerful solution for handling applications like tolerance batching, minimum batching as well as sizing.

New generation – and next-in-line

The SB520 takes over from a long line of Scanvaegt batchers and graders which are still in operation in many companies all over the world. Based on years' of know-how, the new machine has been designed with this in mind which makes it the obvious choice when having to replace an old existing machine, e.g. the Scanvaegt 7100 or 4700.

In doing so, it's possible keep the old separator and infeed in operation instead of having to replace the whole line. This makes the SB520 a very cost-effective solution, which will reduce the cost of investment significantly. Moreover, it contributes to the UN World Goal #12 for sustainable consumption and production patterns.

Next level design

The SB520 is a high-precision weighing machine where all components have been taken to the next level, achieving the very best batching results. Even the weighing belt has been upgraded, making it more accurate and stable. The result is an efficient solution, that reduces give-away to an absolute minimum and provides maximum yield of raw materials.

The Multi-purpose solution

The SB520 represents a fast, precise and sturdy solution, which handles several applications, including:

- Tolerance batching: Intelligent batching products of varying weight into groups to target weight and/or target count with upper and lower limits per batch to minimize give-away.
- Minimum batching: Sorting products of varying weight into groups with either minimum target weight or target count for the total batch.
- Sizing: Sorting products of varying weight into groups with same product weight.

It's also possible run a Multi program, running an advanced combination of all three applications; Tolerance batching, Minimum batching and Sizing.

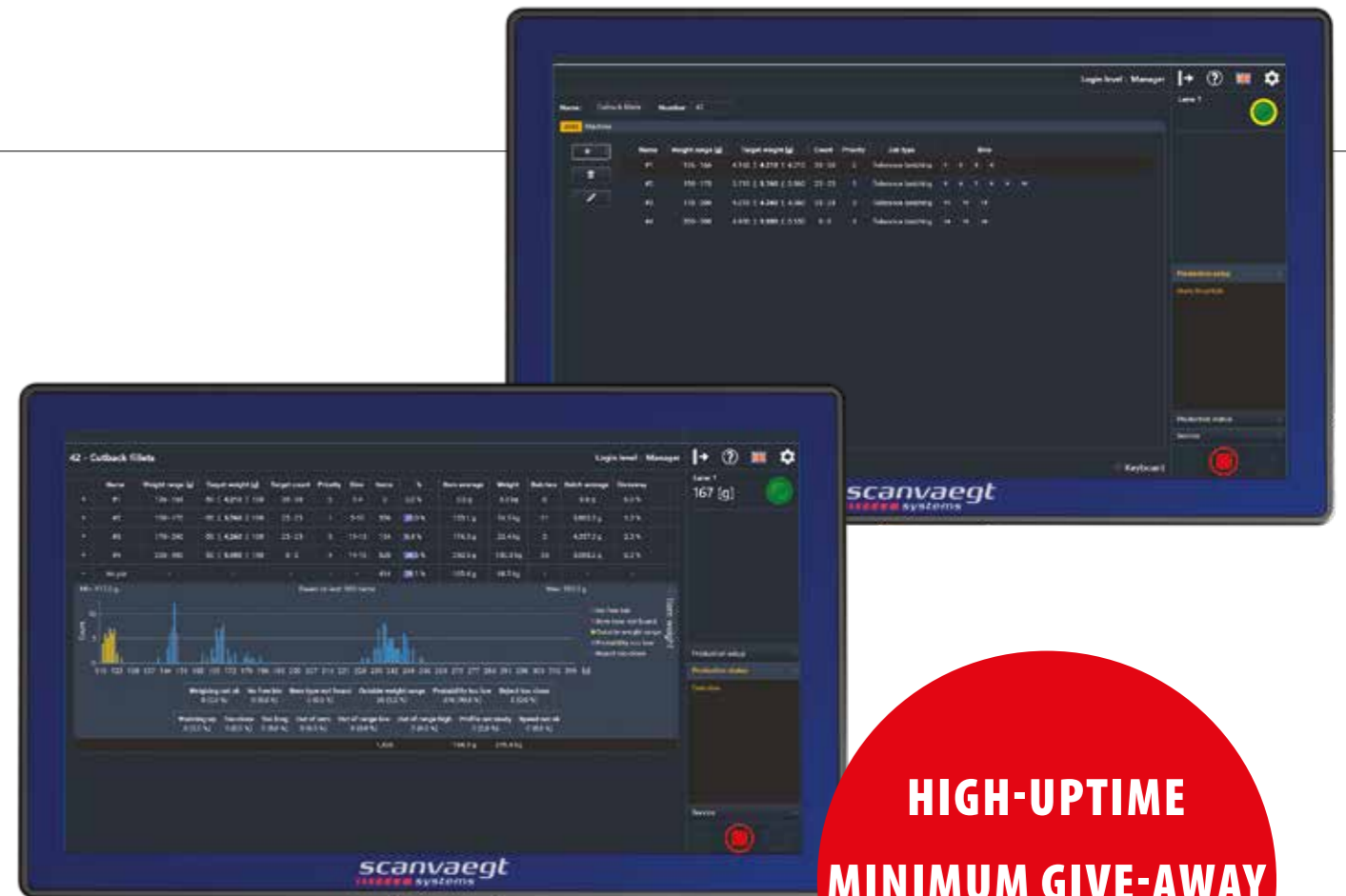

Dedicated new software-system

The new algorithm registers and calculates the weight of all individual products, combines them as close as possible to the target weight of the portion and assigns them to the final batch – everything's takes place at high speed.

The software system, running under a new Windows platform, provides the operator with several strong features for keeping close track of the ongoing job – e.g. the online surveillance system, which provides the operator with a complete overview of the development of the production.

Large, userfriendly operator Interface

The SB520 is equipped with large 18,5" touch-screen with graphic display and intuitive menus, which guide the operator through asking sequences, ensuring quick, easy and error-free operation. The simple navigation structure, clear graphics and easy product setup reduce the time required at product shifts.

The new software system provides complete overview and precise production monitoring using statistics and graphs, fast product setup and the possibility of optimizing production.

HIGH-UPTIME
MINIMUM GIVE-AWAY
MAXIMUM YIELD

Maximum uptime

The simple, yet sturdy design of the SB520 with only few components makes it very reliable and easy to maintain. The slack belt system, which provides fast and accurate weighing, is driven by a hard-wearing drum motor capable of withstanding use in the food industry. Together with the hermetically sealed load cell in stainless steel, the parallelogram construction, the overload protection and an anti-shock system, the SB520 delivers maximum uptime.

The SB520 incorporates remote support connection which enables quick online assistance from Scanvaegt support team in case of technical issues - this will get the machine up and running in no time, and keep downtime to a minimum.

High hygienic standards

Being easy to clean thoroughly, the simple, open construction of the SB520 ensures high hygienic standards. The design with sloping lines and surfaces and round pipe profiles, which facilitate water and detergents to drip off easily, also prevents the accumulation of dirt and bacteria.

Technical Specifications

SB520 ScanBatcher

Materials	Stainless steel	
Display	18,5" 16:9 touch-screen	
Environment	Dry and wet	
Belt width	275 mm	
Weighing bridge length	900 mm	1200 mm
Weighing plate length	250, 300, 350, 400, 500, 600 mm	250, 300, 350, 400, 500, 600, 700, 800, 900 mm
Belt type	Slack belt	
Line height	700 to 2000 mm, steps of 50 mm	
Weighing capacity	3 kg/1 g	
TWR	Up to 300 pcs/min	
Belt speed	15 to 110 m/min	
Power	3 x 400 V + N + PE, 50/60 Hz	
Temperature range	2-30°C.	
Software	Weight grading, minimum batching, tolerance batching and item type	
Options	Top cover, water spray and line control signal and more	
Languages	Danish, English, German, Swedish, Norwegian, Polish	
IP rating	IP66	
IP rating - load cell	IP68	

Subject to change v1/2023.07

SB520

Weighing bridge length 900 mm

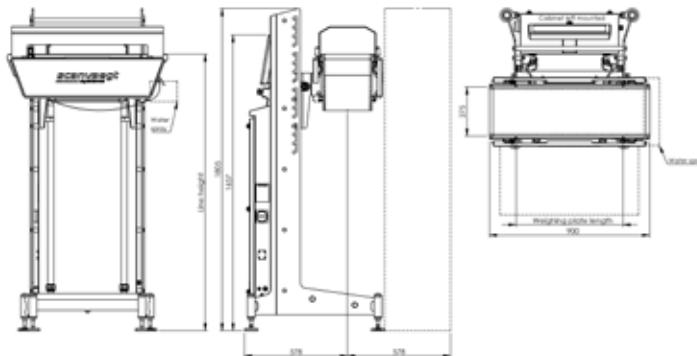

SB520

Weighing bridge length 1200 mm

