



IQ4 Pipeline - Metal Detection System

Designed for the Meat applications

Product Highlights

- Designed on a mobile stand with gas strut for height adjustment the IQ4 Pipeline is made to inspect meat products such as diced, ground, chopped and slurries that is vacuum filled under high pressure.
- Robust components designed for easy strip down cleaning at the end of each product run to comply with hygiene standards (EN1672-2)
- Colour 7" touchscreen control interface including multi-level password access and data logged events for traceability
- IP69K environmental protection suitable for both high-care and low-care environments
- Fully integrated Performance Validation software



7" Touchscreen with a new easy to use interface

Standard across all of the IQ4 range, the big 7" touchscreen offers 33% more space than previous generation metal detectors making operations simple.

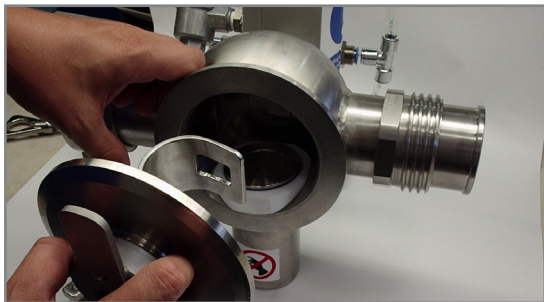

Expertise in Different Product Applications

With over 20 years of research and development in Pipeline applications our experts know the right rejects options for a variety of different products.



Built with filling machines in mind

The IQ4 Pipeline is designed to be compatible with vacuum filling machine brands such as Handtmann, Vemag and Risco.

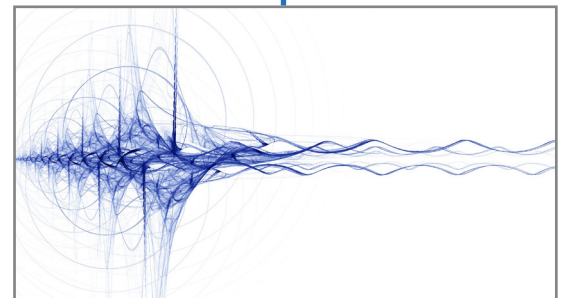

Variable Frequency Provides the Best Detection Levels

The IQ4 is built using LOMA's revolutionary Virable Frequency technology that allows detection levels to be optimised around a wide range of differing product conditions, including whether they are wet or dry.

Technical Specification

Pipe Diameter (")	2.5
Pipe Connections	RD80 - Threaded
Finish	304 stainless steel
Mounting Options	Stand, Hinge (Handtmann)
Supply Voltages	85 to 265 V, 1 ph 50.60 Hz, neutral & Earth
Power Consumption	20VA
Air Supply	5 to 8 Bar (10mm Outside Dia) 72-116 PSI
Temperature Range	-10°C TO + 35°C (14°F to 95°F)
Humidity	0 to 95% Relative Humidity (Non-condensing)
IP Rating	IP69k
PVS Enabled	Yes
Reporting	Batch, Shift
Data Retrieval	Via USB, Ethernet, TRACS
Optional Extras	Remote Control Box, Lampstack

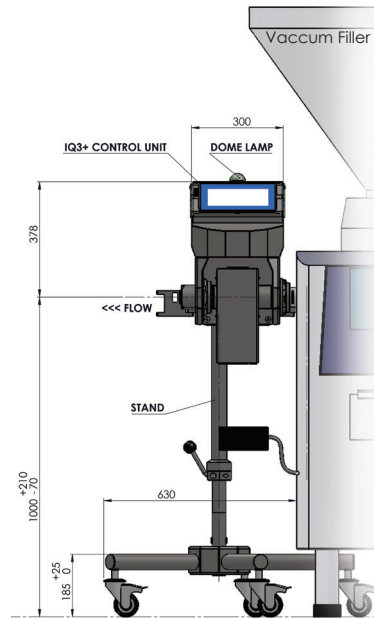

All dimensions in mm, Handtmann VF Filler not Included

Automatic Reject Options

The IQ4 Pipeline can be specified with an automatic reject station with the following options:

	Reject Type	Availabe Sizes (")
Meat	ARI, ARU (Piston) ARL-60 (Rotary)	2.5

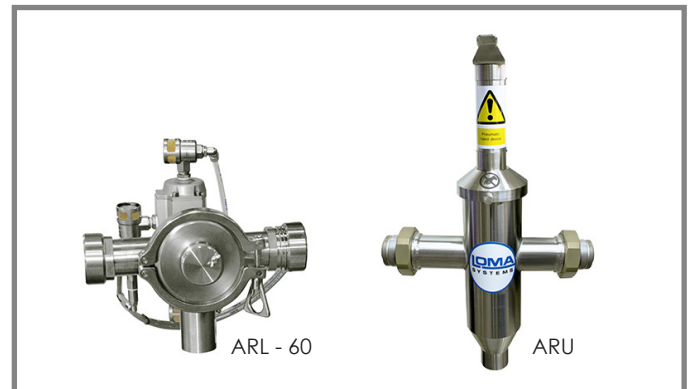

An ITW Company

Loma Systems is a registered trademark of Illinois Tool Works Inc. (ITW). Other names, logos, icons and marks identifying our products and services referenced herein are trademarks of ITW and may not be used without the prior written permission of ITW. Other product and company names listed are trademarks or trade names of their respective companies. Copyright © 2016 Illinois Tool Works Inc. All rights reserved. All of the specifications shown in this document are subject to change without notice.

www.loma.com

Tel: +44(0)1252 893300 (UK) | +1-800-872-LOMA (North America)

Metal Detection | Checkweighing | X-Ray Inspection

In association with

